

# CHARM-100NX



## Video Processing Board 100mm x 100mm x 20mm (3.94" x 3.94" x 0.8")

The Vision4ce CHARM-100NX is a standalone video processing board for embedded video and image processing applications, which is designed to host the GRIP View software. The software includes the field proven DART video tracking software. The CHARM-100NX is based on a NVIDIA Xavier embedded processor which incorporates a multicore ARM processor and powerful GPU. Video interfaces are provided for 6G, 3G, HD and SD video in digital formats.



Tracking and classifying boats at sea

- Multiclass classification and object detection



CHARM 100NX

### Video Interfaces

The CHARM-100NX has the following video interfaces

#### Video Inputs

- 2 x SD/HD/3G/6G SDI

#### Video Outputs

- 2 x SD/HD/3G/6G SDI

Video mezzanine card provides a wide range of expansion options which include CameraLink, CoaxPress and HD component video I/O Expansion options

### VMS Software

The CHARM-100NX hosts the Vision4ce GRIP View software which is a comprehensive real time video management software suite for video and image processing.

The software capabilities with the CHARM-100NX are:

- Video detection & tracking using Vision4ce DART library
- Video streaming
  - MPEG-TS (STANAG 4609)

The following optional capabilities are also available:

- Video streaming
  - RTSP
- Video compression and recording
  - H.264, M-JPEG
- Electronic image stabilization
- Panoramic image formation
- Image enhancement
- Camera control
- Servo platform control
- Dual processing channels

### Architecture

The CHARM-100NX uses a FPGA for high speed, low latency video interfacing and processing combined with the power of the Xavier NX embedded processing which includes the following resources:

- Hexa core ARM CPU
- 384 CUDA core + 48 Tensor core GPU
- Video accelerator for video encode/decode

The Xavier NX provides more than 3 times the AI processing performance of the earlier Jetson TX2 processor and processes two concurrent streams of standard definition or high definition video, selected from the multiple video inputs. The output video is genlocked to the input video and is comprised of low latency video from the selected input combined with processed video and graphics from the Xavier.

### Applications

- Security and surveillance
- UAV & UGV
- Manned vehicles

### Enclosure

A rugged enclosure is available for the CHARM-100NX. The enclosure includes an input power supply which allows the CHARM-100NX to be powered directly from vehicle and aircraft power sources. Customized connector configurations are also available for specific applications..

# CHARM-100NX

The CHARM-100NX is a high-performance standalone video processing board. Video interfaces are provided in digital formats. The primary host interface is through an Ethernet port. Multiple serial links are also provided. The M.2 slot can be used to add up to an SSD, 2 additional Ethernet ports, or other connect.

## Video Inputs

- 2 x digital video inputs
  - SD-SDI, HD-SDI, 3G-SDI, 6G-SDI
  - 480i60, 576i50, 720p50/59.94/60, 1080p25/29.97/30, 1080i50/59.94/60, 1080p50/59.94/60, 2160p25/29.97/30)
- 2 x 2-lane MIPI CSI video inputs
- Expansion options for Camera Link, CoaXPress, Analog, and other video inputs with a mezzanine I/O card.

## Video Outputs

- 2 x digital video outputs
  - SD-SDI, HD-SDI, 3G-SDI, 6G-SDI
  - 480i60, 576i50, 720p50/59.94/60, 1080p25/29.97/30, 1080i50/59.94/60, 1080p50/59.94/60, 2160p25/29.97/30)
- Selectable symbology overlay on outputs
- Mezzanine card can also support video outputs

## Data Interfaces

- 1 x USB 3.0
- 1 x Ethernet
  - 10/100/1000 Base-T
- 4 x Serial RS422
- 1 x CAN bus
- 1 x IRIG DCLS input
- 8 x GPIO (4 inputs, 4 outputs)

## Power

- 12VDC +/-5%,
- <20W

## Expansion

- 1 x M.2 slot (Key M)

## Mechanical

- Dimensions 100 x 100 x 20mm (3.94" x 3.94" x 0.8")

## Environmental

- Temperature
  - Operating -25C to +71C
  - Non-operating -40C to +85C
- Humidity
  - 5% to 95% non-condensing
  - Optional conformal coating available
- Shock
  - 30g, 11ms

Hardware Block Diagram

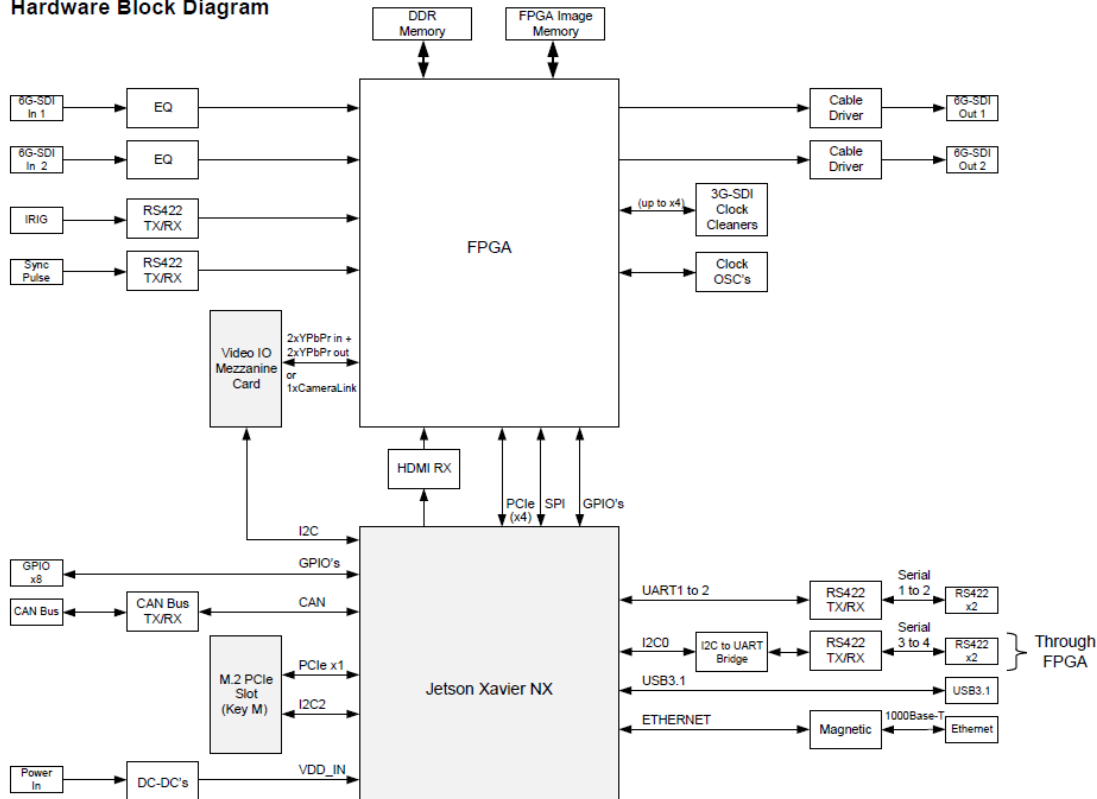

US Supported, Designed and manufactured in the UK