

GRIP VPDU

Rugged Video Processing and Distribution Unit



Hardware

- Latest Intel Core i7 Mobile Processor, Quad Core
- MIL-DTL-38999 connectors
- AMD GPU with 6 display outputs
- 16 or 32 GB DDR3 memory
- Dual 60GB – 600GB SATA II (MIL) SLC/MLC SSDs

I/O Connections

- Serial – 2x RS232/485, 2x RS232
- USB – 2x USB 2.0 (option for additional 2 including USB 3.0)
- Ethernet – 2x 10/100/1000Base-T (additional available)
- MILCAN

Environmental

- Sealed to IP67 – conduction cooled
- Operating temperature (w.r.t. baseplate) -40°C to +71°C
- Storage temperature -40°C to +85°C
- Designed to meet harsh environmental conditions, including MIL-STD-810G and RTCA/DO-160G
- EMC to MIL-STD-461F
- Resilient to large calibre gun shock

Power

- Power – DC 18V to 36V MIL-STD-1275B
- Power consumption – 80 to 150W (configuration dependent)

Operating Systems

- Microsoft Windows embedded 10 IoT
- Ubuntu or CentOS Linux

Mechanical

- Weight 22.0lbs, 10.0kg
- Dimensions 14.37" (d) x 10.83" (w) x 3.97" (h) (365 mm x 275mm x 101mm), excluding connectors and flanges

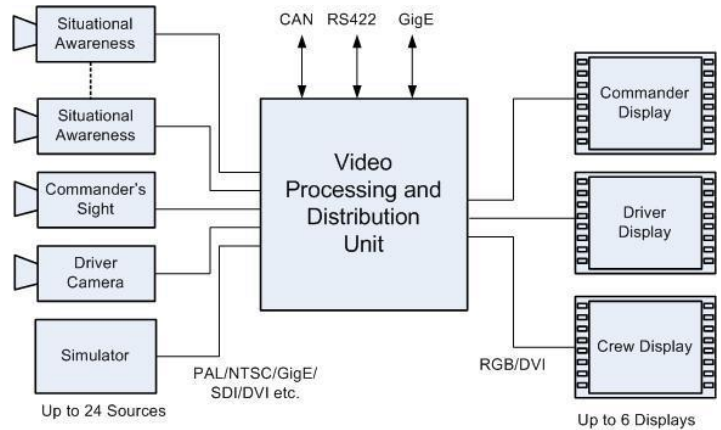

Video Capture

Supports up to 24 diverse video analog and digital video input interfaces, options include:

- RGB, PAL/NTSC
- SD-SDI, HD-SDI (SMPTE 292) up to 1080P60 resolution
- DVI-D, CameraLink, Firewire, GigE Vision, CoaXPress and others

Video Display & Processing

Supports 6 up to independent display outputs, options including Graphic overlay and optimized HMI:

- RGB, VGA, DP, DVI-D, HDMI - configuration dependent
- Panoramic 360 or sector formation
- Extremely low latency video output and distribution
- Target detection and tracking (DART)
- Embedded training mode

Video Compression & Streaming

Flexible streaming of audio, video and metadata over IP, options include:

- Customized SD/HD video and metadata streams
- Embedded metadata overlays
- H.264 compression for recording and streaming (NVL on request)
- Standards include DVI over Ethernet, Def Stan 00-82 and STANAG 4609.

Additional I/O

- MIL-STD-1553 and ARINC 429 interfaces
- Additional Serial, USB, and LAN ports
- GPIO, WiFi, GPS and others.

US and UK Technical Support

GRIP VPDU_DS170801

Specifications subject to change without notice.

©2017 Vision4ce. All rights reserved.

US: 410.384.9181 EU: +44.118.979.7904 info@vision4ce.net www.vision4ce.net